

HUMIDI | HEAT™

heater · humidifier · air washer

OWNER'S MANUAL

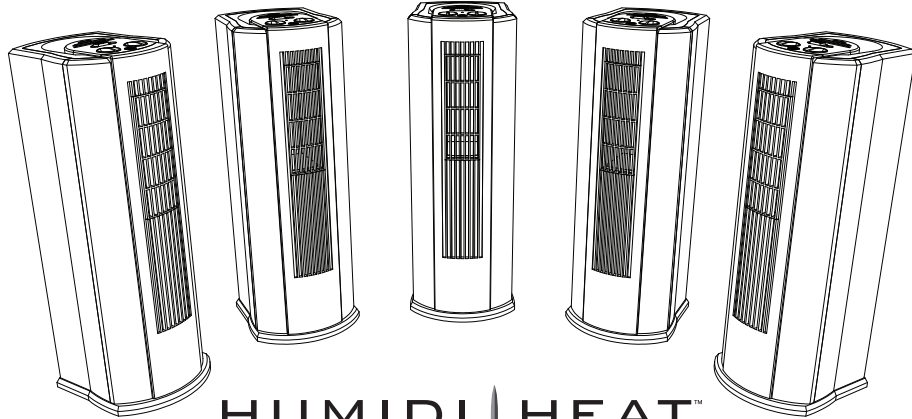

HUMIDI | HEAT™
heater · humidifier · air washer

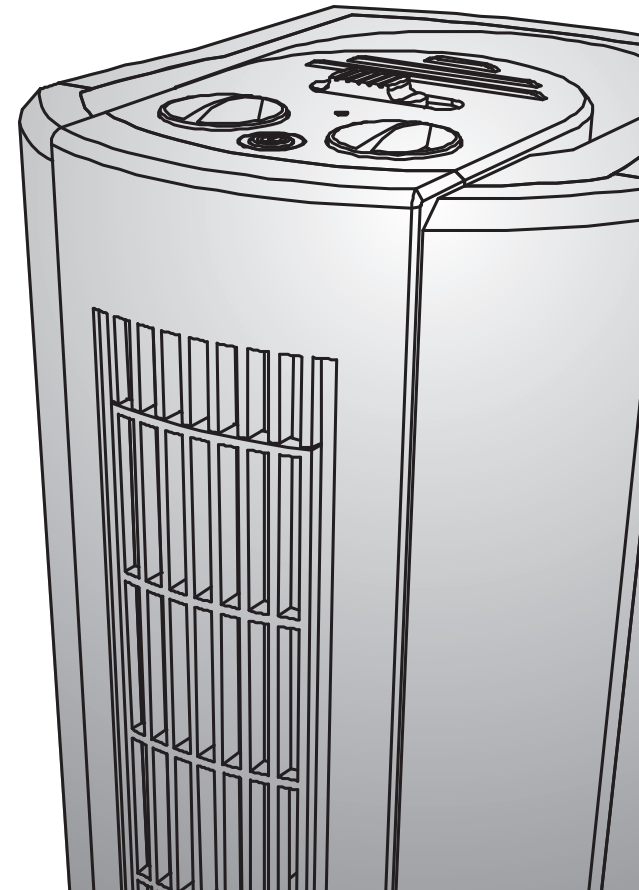

BY
ENVION™
PURE HOME. HEALTHY HOME.

BY
ENVION™
PURE HOME. HEALTHY HOME.

WELCOME

CONGRATULATIONS on your purchase of the HumidiHeat™ combination heater/humidifier! This amazing product combines all the benefits and comforts of a space heater and a humidifier into one space-saving and money-saving product. Once you start using the HumidiHeat™ unit in your home you'll notice instant relief from many of the problems caused by dry air, such as dry skin, swollen nasal passages, headaches, and more. You'll soon agree that the HumidiHeat™ is one product you can't live without!

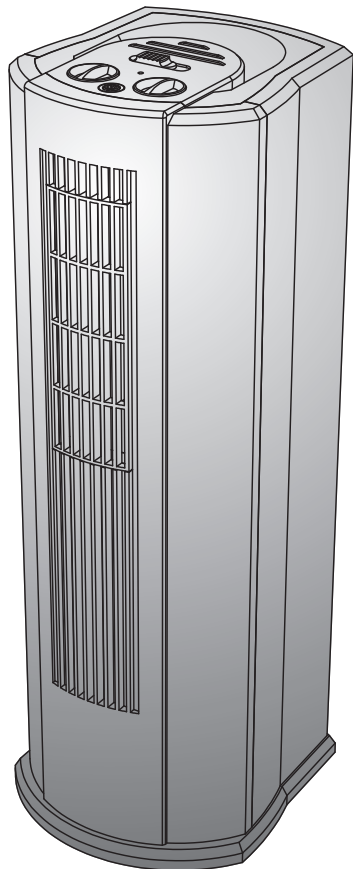

KEEP THIS PRODUCT MANUAL FOR FUTURE REFERENCE.

TABLE OF CONTENTS

IMPORTANT INSTRUCTIONS	1
PRODUCT FEATURES	2
PRODUCT SPECIFICATIONS	2
PRODUCT OVERVIEW	3
ASSEMBLY AND USE	4
PREPARING FOR OPERATION	4
USING THE HUMIDIHEAT™ UNIT	5
CLEANING AND MAINTENANCE	5
CLEANING THE WICK FRAME	5
CLEANING THE WATER TANK	6
TROUBLE SHOOTING	6
WARRANTY INFORMATION	7
ARBITRATION AGREEMENT	8

READ AND SAVE THESE IMPORTANT INSTRUCTIONS

WARNING: RISK OF ELECTRIC SHOCK

When using electrical appliances, basic precautions should always be followed to reduce the risk of fire, electric shock, and injury to persons, including the following:

Read all instructions before using this HumidiHeat™ unit.

1. Extreme caution is necessary when the HumidiHeat™ unit is used near children or invalids and whenever the unit is left operating and unattended. Always supervise children and keep them away from the unit.
2. Do not operate any HumidiHeat™ unit with a damaged cord or plug or after the unit malfunctions, or has been dropped or damaged in any manner. Discard the HumidiHeat™ unit or return it to an authorized service facility for examination and/or repair.
3. Do not use outdoors.
4. This HumidiHeat™ unit is not intended for use in bathrooms, laundry areas or similar indoor locations near water. Never place the HumidiHeat™ unit in a location where it might get wet or fall into a bathtub or other water source.
5. Do not run the cord under carpeting or cover cord with throw rugs, runners, or similar coverings. Do not route cord under furniture or appliances. Arrange cord away from traffic area and where it will not be tripped over.
6. To disconnect HumidiHeat™ unit, turn all controls off, then remove plug from outlet. Do not unplug by pulling on the cord. Do not pull the plug from outlet when unit is turned on.
7. This product is intended for household use only and not for commercial or industrial use.
8. Always unplug the power cord from outlet before opening or filling the water tank. When filling the water tank, use extreme caution to ensure that water is poured only into the water tank and that the rest of the HumidiHeat™ unit does not get wet. Never plug in the unit if it gets wet.
9. If the power cord is damaged, it must be replaced by the manufacturer or a qualified technician.
10. Do not insert or allow foreign objects to enter any ventilation or exhaust opening as this may cause an electric shock, fire or damage the HumidiHeat™ unit.
11. This product operates at 120VAC, 60Hz only.
12. To prevent a possible fire, do not block air intakes or exhaust in any manner. Do not use on soft surfaces, like a bed, where openings may become blocked.

13. Always plug the HumidiHeat™ unit directly into a wall outlet/receptacle. Never use with an extension cord or relocatable power tap (outlet/power strip).
14. **CAUTION** – This heater is hot when in use. To avoid burns, do not let bare skin touch the hot surfaces of the unit. Use the back handle when moving the HumidiHeat™ unit. Keep combustible materials, such as furniture, pillows, bedding, papers, clothes, and curtains at least 3 feet (0.91m) from the front of the heater and keep them away from the sides and rear.
15. This heater has hot and arcing or sparking parts inside. Do not use it in areas where gasoline, paint, or flammable liquids are used or stored.
16. Use this heater only as described in this manual. Any other use not recommended by the manufacturer will void warranty and may cause fire, electric shock, or injury to persons.
17. Do not overfill the water tank as this may cause the risk of electric shock.

SAVE THESE INSTRUCTIONS!

PRODUCT FEATURES

- Durable, washable cloth wick
- LED low water level indicator light
- 3 independent controls settings (Heater, Humidifier, and Heater plus Humidifier)
- 3 fan speed settings and 3 heating power levels (LOW, MEDIUM AND HIGH)
- Self-regulating PTC heater and over-heat protection
- Evaporative humidification eliminates the issue of "white powder"
- Tip-over sensor for smart automatic shutoff control for the whole unit
- Empty water sensor for smart automatic power shutoff for the humidifier

PRODUCT SPECIFICATIONS

- Model:..... HH200M
- Voltage:..... 120 VAC
- Power usage:..... 1500W
- Capacity of Humidification:..... 2.2 gallon/day
- Volume of air flow:..... 80cfm at high setting
- Dry weight:..... 10.8 lbs.
- Product measurements:..... 9.3 x 10.1 x 25.6
- Thermally protected

PRODUCT OVERVIEW

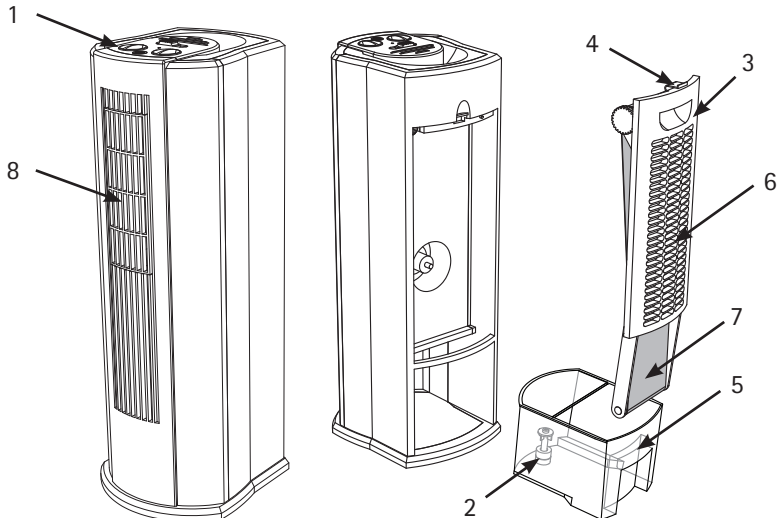

1. Control panel
2. Humidifier water sensor
3. Humidifier wick frame
4. Wick frame release tab
5. Water tank

CONTROL PANEL

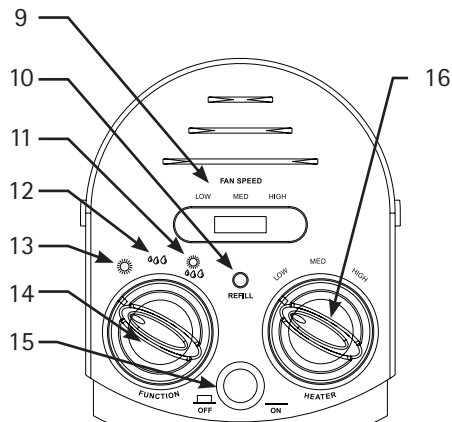

6. Air inlet grill
7. Humidifier wick
8. Air outlet grill
9. Fan speed switch
10. Refill light
11. Heater + Humidifier
12. Humidifier only
13. Heater only
14. Function knob
15. Power button
16. Heater knob

ASSEMBLY AND USE

WARNING: Unplug the HumidiHeat™ unit prior to filling the tank with water

PREPARING FOR OPERATION

1. Open the packing box and take out the HumidiHeat™ unit.
2. Turn the unit upright for operation.
3. To remove the humidifier wick frame, press the release tab and pivot the frame outwards and then lift it out of the unit. **See Figure 1.**
4. Remove the tank by sliding it out of the unit. **See Figure 2.**

5. Fill the water tank with clean water to maximum water level marking on tank. **CAUTION:** Do not overfill the tank.

Use extreme caution to ensure that water is poured only into the water tank and that the rest of the unit stays dry. Never plug in the unit if it gets wet.

6. After filling, put the tank back into the main body and replace the humidifier wick frame.

WARNING: This heater is equipped with a temperature limiting thermostat. If the unit should sense an overheat condition, the element will stop heating. It can only resume operation when user manual reset the unit.

TO RESET HEATER: Unplug the unit and wait 10 minutes for the unit to cool down, then plug unit back and follow the "USING THE HumidiHeat™" instruction described in this manual.

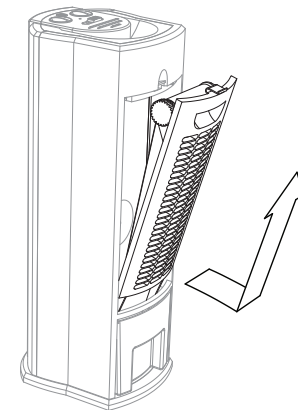

Figure 1

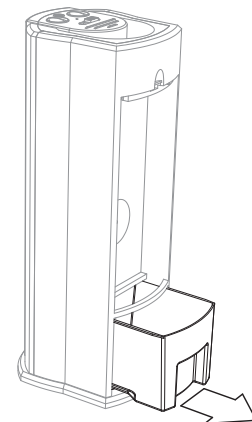

Figure 2

USING THE HUMIDIHEAT™

1. Plug the unit into an electrical outlet and press the power button to turn on your HumidiHeat™ unit.
2. Turn the mode knob to select the desired function. You may choose to use either the heater, the humidifier, or the heater and humidifier together.
3. Once you have chosen the mode you can control how much air passes through your HumidiHeat™ unit by sliding the fan speed button to low, medium or high as you prefer.
4. When you select either the heater mode or the heater + humidifier mode you may control the amount of heat your HumidiHeat™ produces. Choose low, medium or high heat output.

CLEANING AND MAINTENANCE

WARNING: Always unplug the HumidiHeat™ unit prior to cleaning or other maintenance.

CLEANING THE HUMIDIFIER WICK FRAME:

1. Remove the humidifier wick frame as explained in the "ASSEMBLY AND USE" section of this manual.
2. With the humidifier wick frame lying in front of you, gently bend each side of the wick frame to release the bottom roller. See Figure 3.
3. Release the top roller from the frame by carefully bending back the frame bracket and removing the roller axle from the bracket hole. See Figure 4. Remove wick from rollers.
4. To clean the wick you may wash it in your washing machine on a gentle cycle or use a mild detergent to wash by hand. Rinse with clean water. Be sure it is completely dry before reinserting.
5. Reinsert the humidifier wick into the rollers and then insert the humidifier wick frame into the unit.

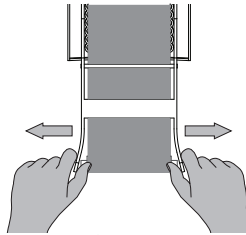
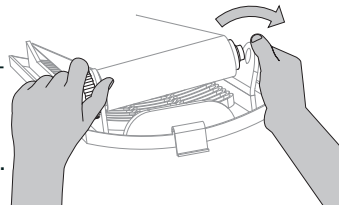
**Figure 3****Figure 4****CLEANING THE WATER TANK:**

1. Remove the humidifier wick frame as shown previously.
2. Remove the water tank as demonstrated earlier in this manual. Clean the tank with water and mild detergent.
3. Rinse thoroughly with clean water before reinstalling. Hand wash only.

STORAGE

Loop the cord around 6-8 inches and wrap with a cord tie. Place the unit in the original box and store in a cool, dry place.

WARNING: Any servicing other than as described in this manual should be performed by an authorized service representative. Do not wash the tank in the dishwasher.

TROUBLE SHOOTING

If you are having problems with your HumidiHeat™, please refer to the following suggestions:

Problem:	My HumidiHeat™ unit will not operate.
Suggestions:	<ul style="list-style-type: none"> • Make sure the power button is pressed and in the down position. • Make sure the unit is plugged into a functioning power outlet. • Verify the wick frame and the inlet grill are properly installed.
Problem:	My HumidiHeat™ unit is not blowing as much air as it used to.
Suggestions:	<ul style="list-style-type: none"> • Verify that the fan speed is set correctly. • Verify that nothing is blocking the air inlet grill or outlet grill.
Problem:	My HumidiHeat™ unit's humidifier feature isn't working.
Suggestions:	<ul style="list-style-type: none"> • Verify there is water in the tank • Verify the humidifier water sensor is floating in the water after filling tank. • Make sure that the water tank is fully inserted.

ONE YEAR LIMITED WARRANTY

Your HumidiHeat™ unit is warranted to be free from defects in materials and workmanship for one year from the original purchase date. Should the product have a defect in materials or workmanship, we will repair or replace it without charge to you (a shipping and processing fee will apply). To obtain service under warranty, simply call our customer service center toll-free at **1-800-875-8577**.

This warranty does not cover damage caused by accident, misuse or any use other than as intended and described in this product manual, or damage resulting from failure to maintain and clean this product as specified in this product manual. This warranty applies only to the original purchaser of the HumidiHeat™ unit.

ALL EXPRESS AND IMPLIED WARRANTIES FOR THIS PRODUCT, INCLUDING IMPLIED WARRANTIES OF MERCHANTABILITY AND FITNESS FOR A PARTICULAR PURPOSE, ARE LIMITED IN DURATION TO THE WARRANTY PERIOD, AND NO WARRANTIES, WHETHER EXPRESS OR IMPLIED, WILL APPLY AFTER THIS PERIOD.

Some states do not allow limitations on the duration of implied warranties, so the above limitation may not apply to you. While this warranty gives you specific legal rights, you may also have other rights which may vary from state to state.

Contact Info for Warranty Service :

HumidiHeat™ by Envion™
 PO Box 9159
 Van Nuys, CA 91409-8291
 1.800.875.8577

customerservice@envionproducts.com
 www.envionproducts.com

©2012 Envion, LLC. All Rights Reserved.

U.S. Patent No. D574,475, EU Patent No. 996285-001, Hong Kong Patent No. 801939.0,
 Japan Patent No. 1358544. Additional patents pending.



ARBITRATION AGREEMENT

PLEASE READ THIS AGREEMENT CAREFULLY. YOU ACCEPT THE TERMS OF THIS AGREEMENT BY RETAINING THE PRODUCT(S) SHIPPED IN CONNECTION WITH THIS AGREEMENT (THE "PRODUCTS") FOR MORE THAN THIRTY (30) DAYS AFTER RECEIPT. IF YOU DO NOT AGREE TO THE TERMS OF THIS AGREEMENT, YOU MAY RETURN THE PRODUCT TO COMPANY WITHIN THIRTY (30) DAYS OF RECEIPT FOR A FULL REFUND.

THIS ARBITRATION AGREEMENT ("AGREEMENT") AFFECTS YOUR LEGAL RIGHTS AND REMEDIES BY PROVIDING THAT DISPUTES BETWEEN YOU AND THE MANUFACTURER, DISTRIBUTOR AND/OR SELLER OF THIS PRODUCT (COLLECTIVELY, "COMPANY"), MUST BE RESOLVED THROUGH BINDING ARBITRATION AND NOT IN COURT. IT ALSO PROVIDES THAT ANY DISPUTE CANNOT BE RESOLVED IN A CLASS ACTION OR OTHER PROCEEDING WHERE YOU REPRESENT OTHER PERSONS OR OTHER PERSONS REPRESENT YOU, AND THAT NO CLASS OR REPRESENTATIVE ARBITRATIONS ARE PERMITTED. PLEASE CAREFULLY READ ALL TERMS IN THIS AGREEMENT.

1. RESOLUTION OF CLAIMS OR DISPUTES.

Any claim or dispute between you and Company (or any of Company's subsidiaries or affiliates) arising out of or relating in any way to the Product or this Agreement shall be resolved through final, binding arbitration. This arbitration obligation is reciprocally binding on both you and the Company and applies regardless of whether the claim or dispute involves a tort, fraud, misrepresentation, product liability, negligence, violation of a statute, or any other legal theory. Both you and Company specifically acknowledge and agree that you waive your right to bring a lawsuit based on such claims or disputes and to have such lawsuit resolved by a judge or jury.

2. LIMITATION OF LEGAL REMEDIES.

All arbitrations under this Agreement shall be conducted on an individual (and not a class-wide) basis, and an arbitrator shall have no authority to award class-wide relief. You acknowledge and agree that this Agreement specifically prohibits you and the Company from commencing arbitration proceedings as a representative of others or joining in any arbitration proceedings brought by any other person. The parties agree that no class or representative actions of any type are permitted.

3. ARBITRATION PROCEDURES.

- Before instituting an arbitration, if you have any dispute, we strongly encourage you to contact the Company to try to resolve the matter by calling 800-218-3560, although you are not required to do so.
- The arbitration of any claim or dispute under this Agreement shall be conducted in accordance with the expedited procedures set forth in the JAMS Comprehensive Arbitration Rules and Procedures as those Rules exist on the date you receive the Product, including Rules 16.1 and 16.2 of those Rules. These rules and procedures are available by calling JAMS or by visiting its web site at www.jamsadr.com. The arbitration of any claim or dispute under this Agreement shall be conducted by an arbitrator who has at least five years of experience conducting arbitrations.
- The arbitration of any claim or dispute under this Agreement shall be conducted in the State of California or the location in which you received this Agreement. For claims of \$10,000 or less, you may choose whether the arbitration proceeds in person, by telephone, or based only on submissions.
- The Company shall pay costs for the arbitration of claims, including any JAMS Case Management Fee and all professional fees for the arbitrator's services. The Company shall pay the fees and costs of its own counsel, experts and witnesses and shall not be able to recoup them from you even if you do not prevail in the arbitration. Unless otherwise provided by law, you acknowledge and agree that you shall pay the fees and costs of your own counsel, experts and witnesses.

4. CHOICE OF LAW.

The arbitration provisions of this Agreement and any arbitration conducted pursuant to the terms of this Agreement shall be governed by the Federal Arbitration Act (9 U.S.C. Secs. 1-16). In this respect, the parties acknowledge that this Agreement involves a transaction conducted in interstate commerce. Otherwise, this Agreement and the rights of the parties hereunder shall be governed by and construed in accordance with the laws of the State of California, exclusive of conflict or choice of law rules.

5. SEVERABILITY.

If any provision of this Agreement is declared or found to be unlawful, unenforceable or void, such provision will be ineffective only to the extent that it is found unlawful, unenforceable or void, and the remainder of the provision and all other provisions shall remain fully enforceable.